

Locomarine



ADD-ON MODULE

NETWORK EXTENDER

SERIES 5

The easiest way to stay online.

Installation Manual

version 1.0

Read carefully.

For better understanding check video tutorials on our website.

Register your product for software update notifications.

Thank you.

COPYRIGHT NOTICE

Locomarine Networks d.o.o. reserves the rights to alter the products described in this manual at any time without prior notice. This document contains proprietary information protected by copyright. All rights are reserved. No part of this manual may be reproduced by any mechanical, electronic, or other means in any form without prior written permission of the manufacturer. Information provided in this manual is intended to be accurate and reliable. However, Locomarine Networks d.o.o. assumes no responsibility for use of this manual, nor for any infringements upon the rights of third parties, which may result from such use.

RoHS COMPLIANT

All devices in the Yacht Router series comply with the Restriction of Hazardous Materials (RoHS) Directive. This means that all components used to build Yacht Router and add-on modules are RoHS compliant. The RoHS Directive bans placing on the EU market new electrical and electronic equipment containing more than agreed levels of lead, cadmium, mercury, hexavalent chromium, polybrominated biphenyl (PBB) and polybrominated diphenyl ether (PBDE) flame retardants.

INTRODUCING YACHT ROUTER SOLUTION

Yacht Router with add-on modules is a complete network infrastructure solution for yacht or boat of any size. Yacht Router devices with add-on modules will help you to easily install, setup and control Internet connection on your yacht. The most important part of Yacht Router solution is the software which controls complete system. It is designed by professionals specialized in yacht communication systems in collaboration with experienced yacht captains. The result is a system that is simple to operate, maintain and control. Underneath simple touch user interface, Yacht Router with add-on modules is a solution with an industry level of reliability, performance and unprecedented level of security.

DISCLAIMER AND WARNING

The contents of this manual are well prepared by Locomarine Networks d.o.o.

While we try to improve our equipment at all times, Locomarine Networks d.o.o. shall incur no liability based on contents, updates or modification of the contents, or the lack of contents in this manual.

Because of the nature of wireless communications, transmission and reception of data can never be guaranteed. Data may be delayed, corrupted (i.e. have errors) or be totally lost. Although significant delays or losses of data are rare when wireless devices such as the Yacht Router are used in a normal manner with a well-constructed network, the Yacht Router device and additional modules should not be used in situations where failure to transmit or receive data could result in damage of any kind to the user or any other party, including but not limited to personal injury, death, or loss of property. Locomarine Networks d.o.o. and its affiliates accept no responsibility for damage of any kind resulting from delays or errors in data transmitted or received using the Yacht Router device, or for failure of the Yacht Router device to transmit or receive such data.

The equipment said in this manual must only be used for what it was designed.

Improper operation or installation may cause damage to the equipment or personal injury. Locomarine Networks d.o.o. will not incur any liability of equipment damage or personal injury due to improper use or installation of the equipment. It is strongly recommended to read this manual and the following safety instructions before proceeding to installation or operation.

SAFETY AND HAZARD

Do not operate your Yacht Router and/or add-on modules:

In areas where blasting is in progress.

Where explosive atmospheres may be present including refuelling points, fuel depots, and chemical plants.

Near medical equipment, life support equipment, or any equipment which may be susceptible to any form of radio interference.

In such areas, Yacht Router and add-on modules **MUST BE POWERED OFF**. Otherwise, they can transmit signals that could interfere with this equipment.

In an aircraft, the Yacht Router and add-on modules **MUST BE POWERED OFF**. Otherwise, the Yacht Router and add-on modules can transmit signals that could interfere with various on-board systems and may be dangerous to the operation of the aircraft or disrupt the cellular network. Use of cellular and WIFI equipment in an aircraft is illegal in some jurisdictions. Failure to observe this instruction may lead to suspension or denial of cellular services to the offender, or legal action or both.

IMPORTANT: It is solely on end-user to set transmitting power value for WIFI Booster to comply with regulations of country where product will be used. Regulations and online WIFI power calculators (EIRP - Equivalent Isotropically Radiated Power) are widely available on the Internet. Locomarine Networks d.o.o. cannot be responsible by any means for improper setup. Transmission power is set and regulated via Yacht Router Control software.

IMPORTANT: Exposure to Radio Frequency Radiation.

63 cm minimum distance has to be maintained between device and the occupational user and 142 cm to general public. Under such configuration, the FCC radiation exposure limits set forth for an population/uncontrolled environment can be satisfied.

WARNING: It is installer's responsibility to ensure that when using the authorized antennas in the United States (or where FCC rules apply); only those antennas certified with the product are used. The use of any antenna other than those certified with the product is expressly forbidden in accordance to FCC rules CFR47 part 15.204. The installer should configure the output power level of antennas, according to country regulations and per antenna type. Professional installation is required of equipment with connectors to ensure compliance with health and safety issues.

SAFETY INSTRUCTIONS

ELECTRICAL SHOCK HAZARD: Do not open enclosure of the equipment if you are not qualified to do it.

TURN OFF THE POWER IMMEDIATELY IF WATER LEAKS INTO THE EQUIPMENT OR AN OBJECT DROPS INTO THE EQUIPMENT:

Continue operating the equipment could cause electrical shock or fire. Contact your nearest distributor or dealer for service.

DO NOT DISASSEMBLE THE EQUIPMENT OR MODIFY THE EQUIPMENT: Improper disassemble or modification could cause electrical shock, fire, or personal injury.

AVOID OPERATING THE EQUIPMENT WITH WET HANDS: Electrical shocks could be resulted if operating with wet hands.

USE PROPER FUSE: Damage to the equipment or fire could be resulted if using improper fuse.

TURN OFF THE POWER IMMEDIATELY IF THE EQUIPMENT IS EMITTING SMOKE OR FIRE: Continue operating the equipment could cause electrical shock or fire. Contact your nearest distributor or dealer for service.

DO NOT PLACE ANY LIQUID-FILLED CONTAINER ON TOP OF THE EQUIPMENT.

INTRODUCTION

ABOUT NETWORK EXTENDER 7
WHAT IS IN THE PACKAGE 8
PORTS AND CONNECTORS 9

INSTALLATION

CONNECTING POWER SUPPLY 10
CONNECTING NETWORK EXTENDER TO YACHT ROUTER 11
SETUP 15

TECHNICAL SPECIFICATIONS

HARDWARE DETAILS 16
OUTLINE DRAWINGS 17

1.1. ABOUT NETWORK EXTENDER

Network Extender is essential part of Yacht Router network infrastructure solution. It will give you ability to extend WIFI/Ethernet coverage on larger vessels. You can connect multiple WIFI Extenders, depending on Yacht Router model and vessel size.

Each Network Extender will propagate Backbone all Vessel Networks (e.g. Guest WIFI, Crew WIFI) depending on Yacht Router model it is connected to. Depending on Yacht Router model you can connect multiple Network Extenders. It is connected to Yacht Router via single PoE (Power over Ethernet) cable for simultaneous power and data transfer. Each Network Extender is equipped with four additional LAN ports so you can easily connect more Network Extenders or other devices. If you need to add multiple Network Extenders you can use star or chain topology to provide connectivity no matter the size of your vessel.

Network Extender cannot operate without Yacht Router.

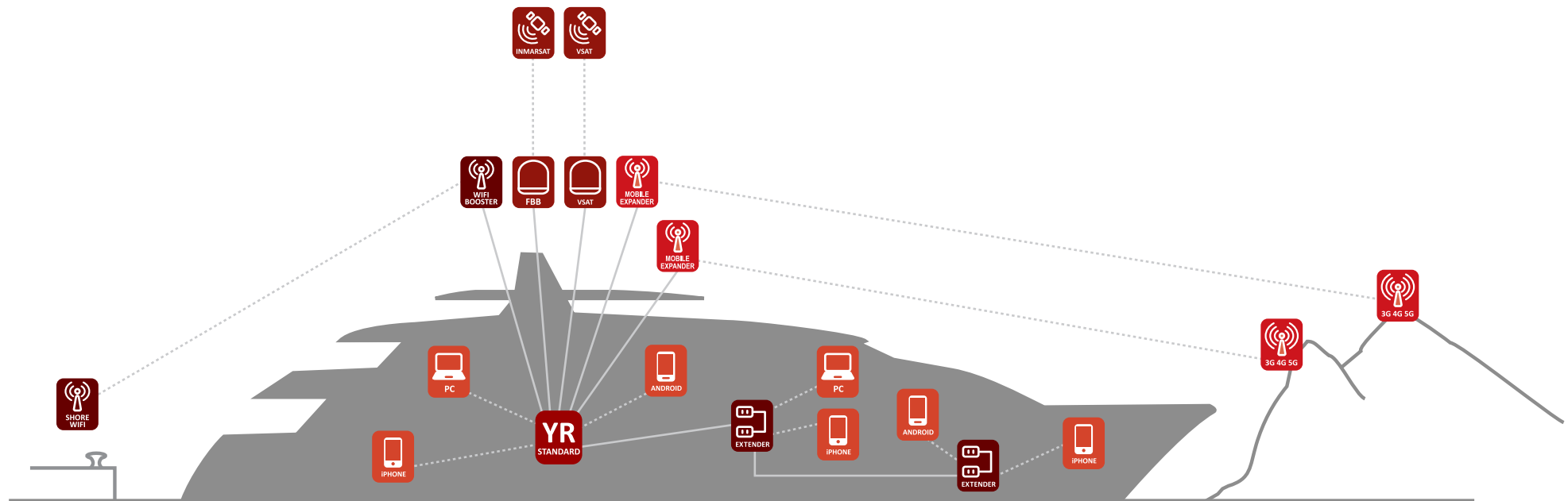

1.2. WHAT IS IN THE PACKAGE

When shipped, all devices are wrapped in plastic bags that protect them from humidity. Devices are then placed into a cardboard box. A bag containing accessory items is placed inside the box too. List of all included components is enclosed in the package.

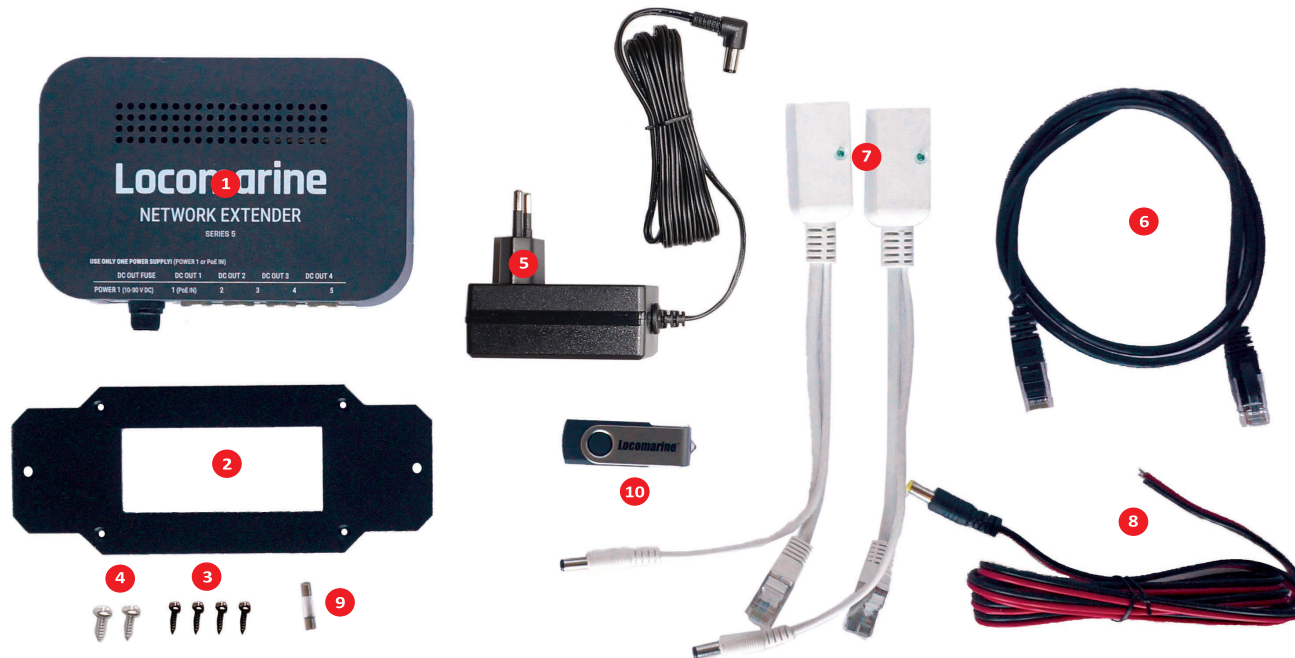

- 1 - Network Expander, ME-S05, 1 pcs
- 2 - Wall mount (Network Extender s5), WMM-02, 1 pcs
- 3 - Fixing screw (Wall mount), FSC-02, 4 pcs
- 4 - Fixing screw, FSC-01, 2 pcs
- 5 - AC/DC power supply 24V/0.8A, PSU-05, 1 pcs
- 6 - CAT5 cable (with connectors, 1m), CAT5-02, 1 pcs
- 7 - Gigabit PoE injector (female), CAT5P-03, 2 pcs
- 8 - DC power cable with connector 2 m, PWC-01, 1 pcs
- 9 - Fuse 1,5 A (spare), FUS-02, 1 pcs
- 10 - Manuals & control software (on USB stick), QIG-00, 1 pcs

1.3. PORTS AND CONNECTORS

Network Extender is equipped with following ports and connectors.

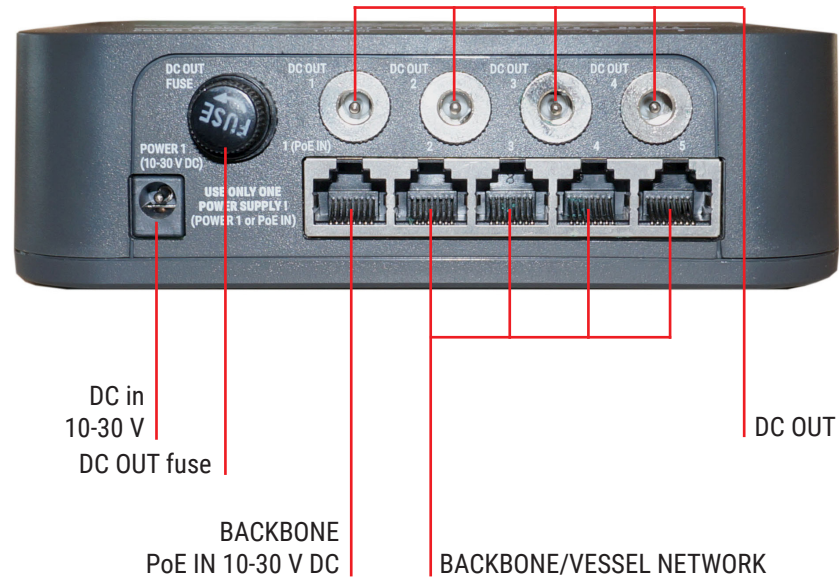

2.1. CONNECTING POWER SUPPLY

There are few ways to power Network Extender:

- **DC in 10-30 V** connector directly from vessel battery (with supplied DC power cable with connector 2 m)
- **DC in 10-30 V** connector using supplied AC/DC power adaptor
- **ETH POE IN 10-30 V** connector using POE (Power-Over-Ethernet) injector

Most common way to connect Network Extender is directly from the Yacht Router using PoE injector.

You can also power Network Extender directly from vessel battery using 2 m supplied DC power cable. Power cable consist of RED and BLACK wire. Connect RED wire to positive (+) and BLACK wire to negative (ground -) power source on your vessel power supply system (battery).



IMPORTANT

Never connect more than one power source at the same time. Connecting multiple power supplies at the same time can damage Mobile Expander and void a warranty.
 Wrongly connected DC power cable can damage Mobile Expander and void a warranty.
 Voltage lower than 10 V and higher than 30 V can damage Mobile Expander and void a warranty.

2.2. CONNECTING NETWORK EXTENDER TO YACHT ROUTER

Depending on Yacht Router model you can connect different number of Network Extenders:

Yacht Router Micro - 1
Yacht Router Mini - 5
Yacht Router Standard - 20
Yacht Router Pro - 50

To use Network Extender it must be connected to Backbone port on the Yacht Router. Backbone port is designated port for Backbone Network. Backbone Network is dedicated network used for communications between Yacht Router and Add-on modules (Network Extenders, WIFI Boosters, Mobile Expanders etc).

Backbone Network cannot provide Internet access. In example, if you connect computer via Ethernet cable to Backbone port, computer will not be able to access the Internet.

By default, all five Ethernet ports on Network Extender are set as Backbone ports and therefore designated to Backbone Network. All ports except port 1 can be designate to Vessel Networks of your choice.

Example:

On 30 m yacht you installed Yacht Router Standard. It can establish three different Vessel Networks (e.g. Guest, Crew, Captain). Each of this Vessel Networks will be available via network cable or wirelessly. As this is quite large yacht, WIFI is not available on all deck and cabins. Therefore, you decided to install Network Extender in Guest cabin so guest can access Internet wirelessly via Guest WIFI network. As Network Extender is equipped with four Ethernet ports you want to set them to be part of same Guest Network. That way you can be sure that guest will still use same (Guest) network even if they connect to Network Extender via network cable.

The change Ethernet ports designation on Networks Extender you have to connect Yacht Router to Support Network and contact our Support Team to do it remotely for you. Please check your Yacht Router manual how to do it.

On a following photo you can see how to connect single Network Extender to Yacht Router Mini using PoE injector (supplied with a package) and Ethernet cable. You can also see WiFi Booster connected to Backbone port on Yacht Router.



On a following photo you can see how to connect single Network Extender to Yacht Router Mini using PoE injector (supplied with a package) and Ethernet cable.



Example how to use Network Extenders on larger installations.

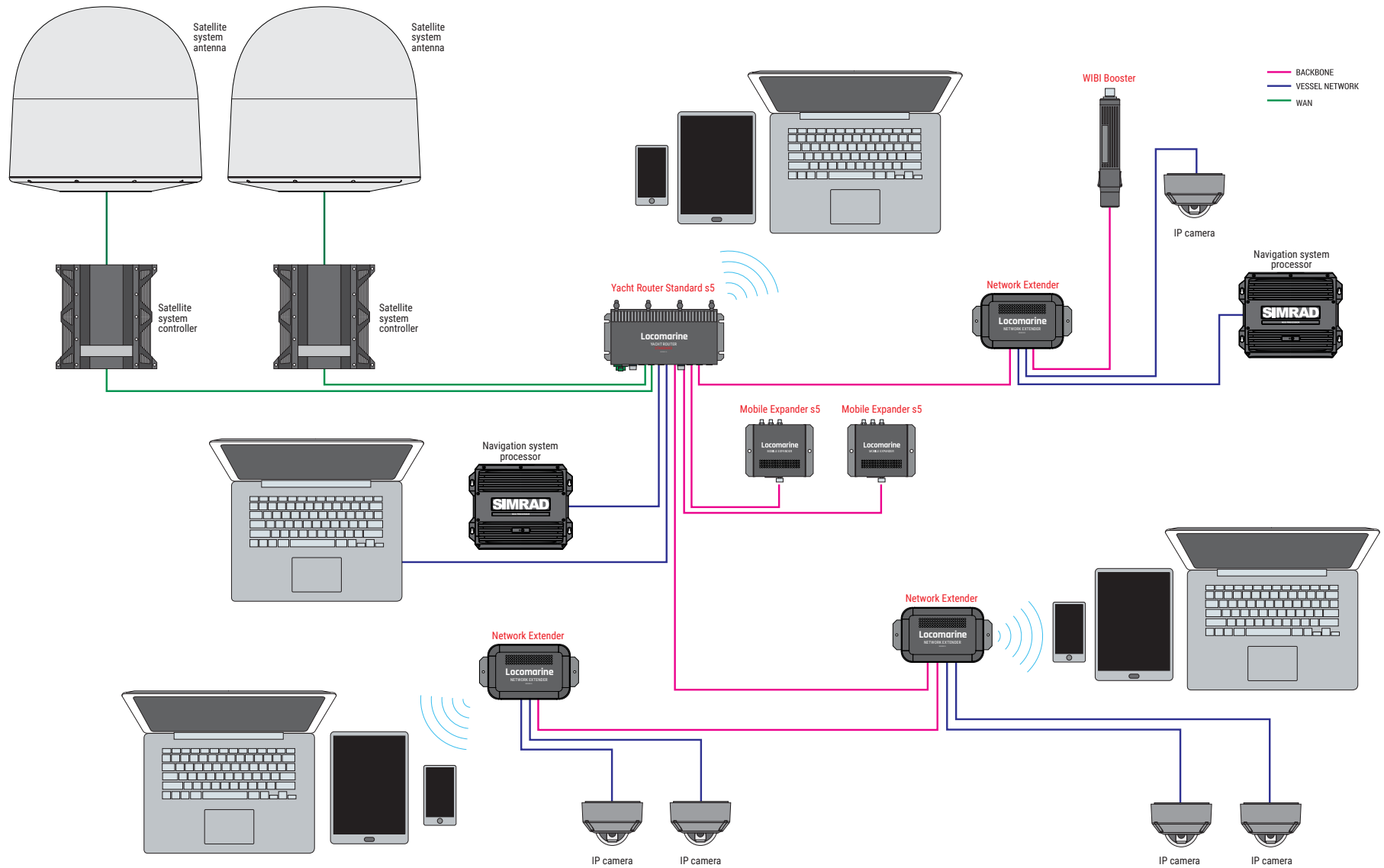

2.3. SETUP

As Network Extender is add-on module to the Yacht Router it is controlled by same software you use for your Yacht Router. If you did not already installed Yacht Router Control software you can download it here:



Once you install the software refer to USER MANUAL how to use it. It is available for download on our website www.yachtrouter.com

You can also check VIDEO TUTORIALS on our website www.yachtrouter.com

3.1. HARDWARE DETAILS

LAN, Backbone ports

Total number of Ethernet ports: 5
Ethernet Backbone ports: up to 5 (min. 1)
Ethernet Vessel Network (LAN) up to 4
Max. data rate on each Backbone port: 1 Gbps

Vessel networks (WIFI/LAN)

Max. number of networks: depending on Yacht Router
Supported standard: 2.4 GHz (b/g/n), 5 GHz (a/n/ac)
Max. WIFI data rates on 2.4 GHz: 300 Mbps
Max. WIFI data rates on 5 GHz: 1733 Mbps
Max. WIFI transmit power on 2.4 GHz: 29/794 dBm/mW
Max. WIFI transmit power on 5 GHz: 33/1995 dBm/mW
Sensitivity of integrated antenna (2.4/5 GHz): 1.5/1.5 dB

Power, environment and dimensions

DC power supply input range: 12-30 V
Max. power consumption: 16 W
Operating temperature range for internal unit: -30 to +50 °C
Operating humidity range: 5-95 % non-condensing
IP Protection: IP30
Dimension (WxDxH, without antennas): 150 x 100 x 48 mm

3.2. OUTLINE DRAWINGS

All dimensions in mm.

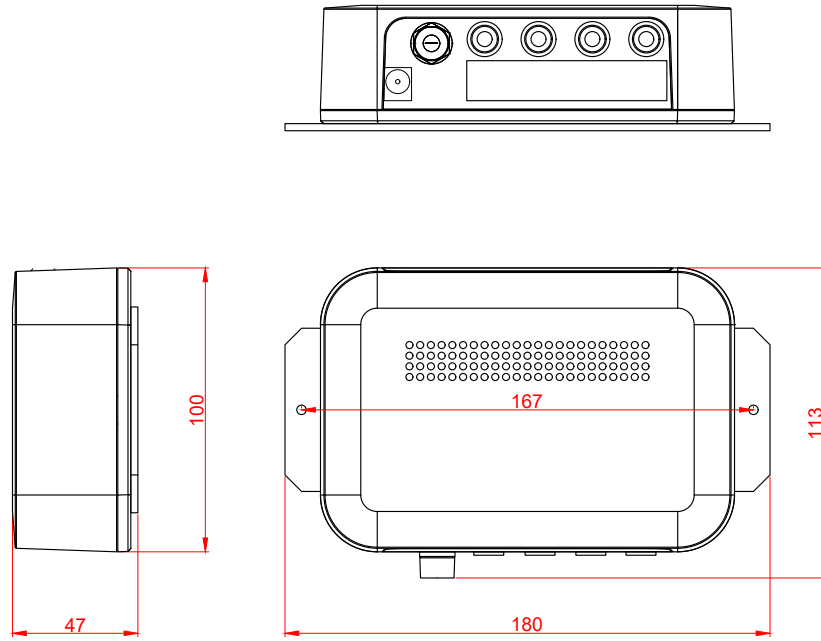

Network Extender - Series 5

LOCOMARINE NETWORKS d.o.o. LIMITED FACTORY WARRANTY

Locomarine Networks d.o.o. manufactures marine electronic products which are marketed and supported worldwide via the Locomarine Networks d.o.o. distributor, dealer and partner network. Each and every Locomarine Networks d.o.o. distributor, dealer and partner is committed to service and support the products in accordance with the market's needs and requirements. In addition, the Locomarine Networks d.o.o. distributor, dealer and partner networks are obliged to support the products irrespective of who sold and installed the product. Locomarine Networks d.o.o. Limited Factory Warranty for Yacht Router products can be downloaded from www.yachtrouter.com under Support/Download section.

DECLARATION OF CONFORMITY

Hereby, Locomarine Networks d.o.o. declares that this Yacht Routers and add-on modules are in compliance with the essential requirements and other relevant provisions of Directive 2014/53/EC. Declaration of Conformity is available for download on www.yachtrouter.com.

IMPORTANT: It is solely on end-user to set transmitting power value for all Yacht Router WIFI components to comply with regulations of country where product will be used. Regulations and online WIFI power calculators (EIRP - Equivalent Isotropically Radiated Power) are widely available on the Internet. It is solely up to user to comply with country regulations and Locomarine Networks d.o.o. cannot be responsible by any means for improper setup. Transmitting power is set and regulated via Yacht Router Control software.

FCC INTERFERENCE STATEMENT

This FCC statement is related to Network Extender model ME-S05.

This device contains FCC ID: TV7RBD52-5ACD2ND. This equipment has been tested and found to comply with the limits for a Class B digital device, pursuant to Part 15 of the FCC Rules. These limits are designed to provide reasonable protection against harmful interference in a residential installation.

This equipment generates, uses and can radiate radio frequency energy and, if not installed and used in accordance with the instructions, may cause harmful interference to radio communications. However, there is no guarantee that interference will not occur in a particular installation. If this equipment does cause harmful interference to radio or television reception, which can be determined by turning the equipment off and on, the user is encouraged to try to correct the interference by one of the following measures:

- Reorient or relocate the receiving antenna.
- Increase the separation between the equipment and receiver.
- Connect the equipment into an outlet on a circuit different from that to which the receiver is connected.
- Consult the dealer or an experienced radio/TV technician for help.

FCC Caution: Any changes or modifications not expressly approved by the party responsible for compliance could void the user's authority to operate this equipment.

This device complies with Part 15 of the FCC Rules. Operation is subject to the following two conditions: (1) This device may not cause harmful interference, and (2) this device must accept any interference received, including interference that may cause undesired operation.

This device and its antennas must not be co-located or operated in conjunction with any other antenna or transmitter.

IMPORTANT: Exposure to Radio Frequency Radiation.

63 cm minimum distance has to be maintained between the antenna and the occupational user and 142 cm to general public. Under such configuration, the FCC radiation exposure limits set forth for a population/uncontrolled environment can be satisfied.

INDUSTRY CANADA NOTICE TO USERS

Notice: To satisfy IC RF exposure requirements for mobile and base station transmission devices, a separation distance of 63 cm or more should be maintained between the antenna of this device and persons during operation. To ensure compliance, operation at closer than this distance is not recommended. The antenna(s) used for this transmitter must not be co-located or operated in conjunction with any other antenna or transmitter.

Avis: Pour répondre à la IC d'exposition pour les besoins de base et mobiles dispositifs de transmission de la station, sur une distance de séparation de 63 cm ou plus doit être maintenue entre l'antenne de cet appareil et les personnes en cours de fonctionnement. Pour assurer le respect, l'exploitation de plus près à cette distance n'est pas recommandée. L'antenne (s) utilisé pour cet émetteur ne doit pas être co-localisés ou fonctionner conjointement avec une autre antenne ou transmetteur.

